











ASSEMBLY INSTRUCTIONS

ITEM NO : B8270 / B8280 - K - HBFB
KING HEADBOARD / FOOTBOARD

**(BOX 1)
BOX OF HEADBOARD / FOOTBOARD**

ITEM	DRAWING	DESCRIPTION	QTY
A		HEADBOARD PANEL	1
B		LEFT HEADBOARD LEG	1
C		RIGHT HEADBOARD LEG	1
D		FOOTBOARD	1
E		WOODEN SLAT	4
F		WOODEN SUPPORT	8

**(BOX 1) HEADBOARD / FOOTBOARD
HARDWARE LIST**

ITEM	DRAWING	DESCRIPTION	QTY
1		ALLEN WRENCH (M4)	1
2		CONNECTION BOLT (M6 x 50mm) W/WASHER & SPRING WASHER	8
3		CONNECTION BOLT (M6 x 25mm) W/WASHER & SPRING WASHER	8
4		FLAT HEAD SCREW (#8 x 1 1/8")	8
5		Assembly Tool Not Included	1

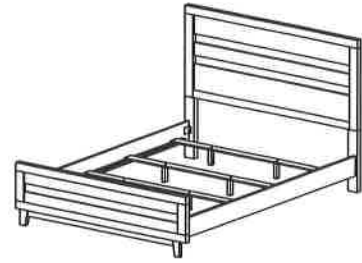

**COMPLETED KING BED
ASSEMBLY**

**(BOX 2)
BOX OF SIDE RAIL**

ITEM	DRAWING	DESCRIPTION	QTY
G		SIDE RAIL	2

**(BOX 2) SIDE RAIL
HARDWARE LIST**

ITEM	DRAWING	DESCRIPTION	QTY
6		WOOD DOWEL (M8 x 30mm)	8

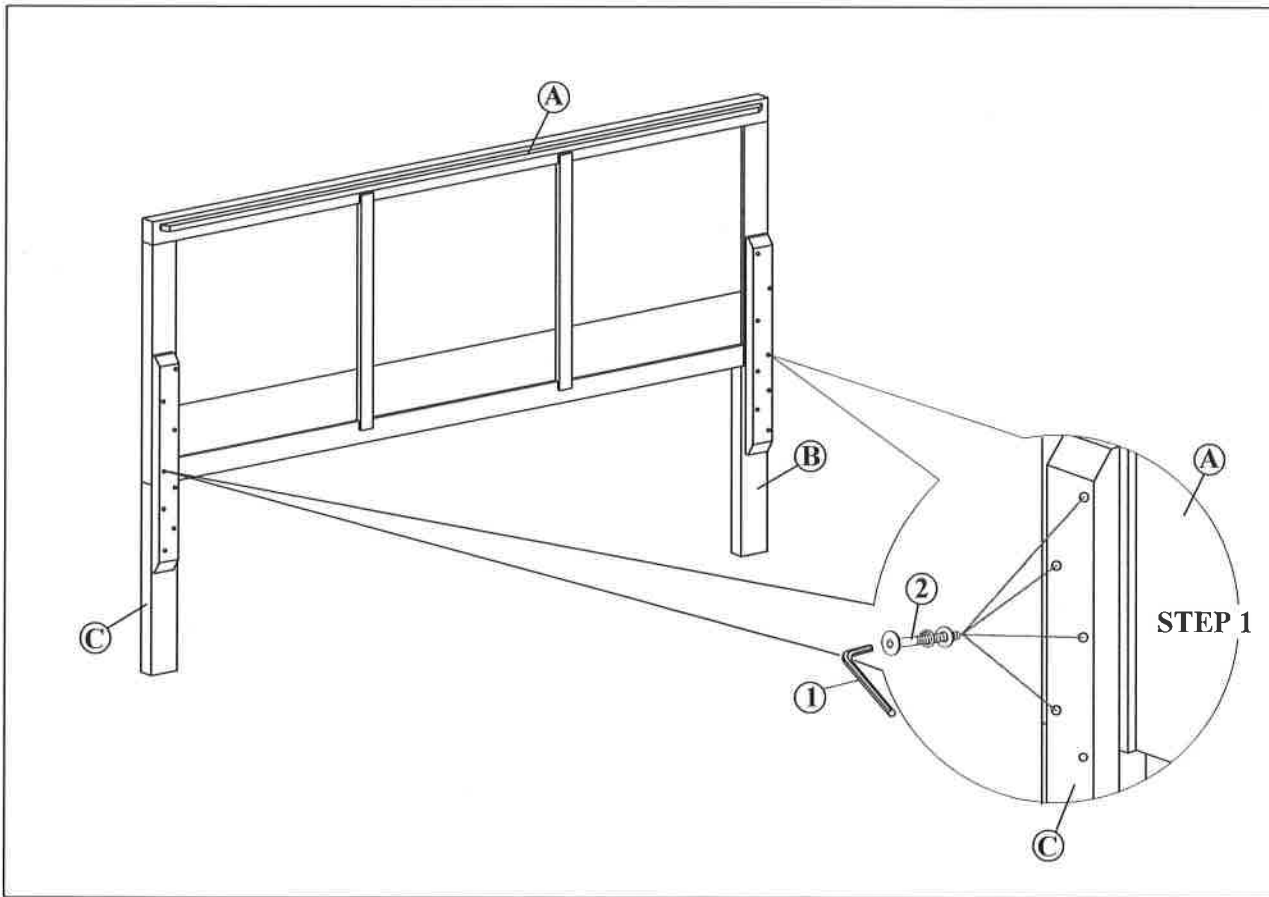

THE HARDWARE IS LOCATED IN THE PACKING ITEMS

NOTE : MUST TIGHTEN SCREWS PERIODICALLY. WITH USE SCREW MAY BECOME LOOSE.
CHECK TIGHTNESS OF ALL SCREW EVERY 6-8 WEEKS.

CLEANING INSTRUCTION

After assembly, clean & polish the completed parts if necessary with soft cloth and industrial recognized furniture polish

ASSEMBLY INSTRUCTIONS

ITEM NO : B8270 / B8280 - K - HBFB
KING HEADBOARD / FOOTBOARD

OPTION 1 - KING BED

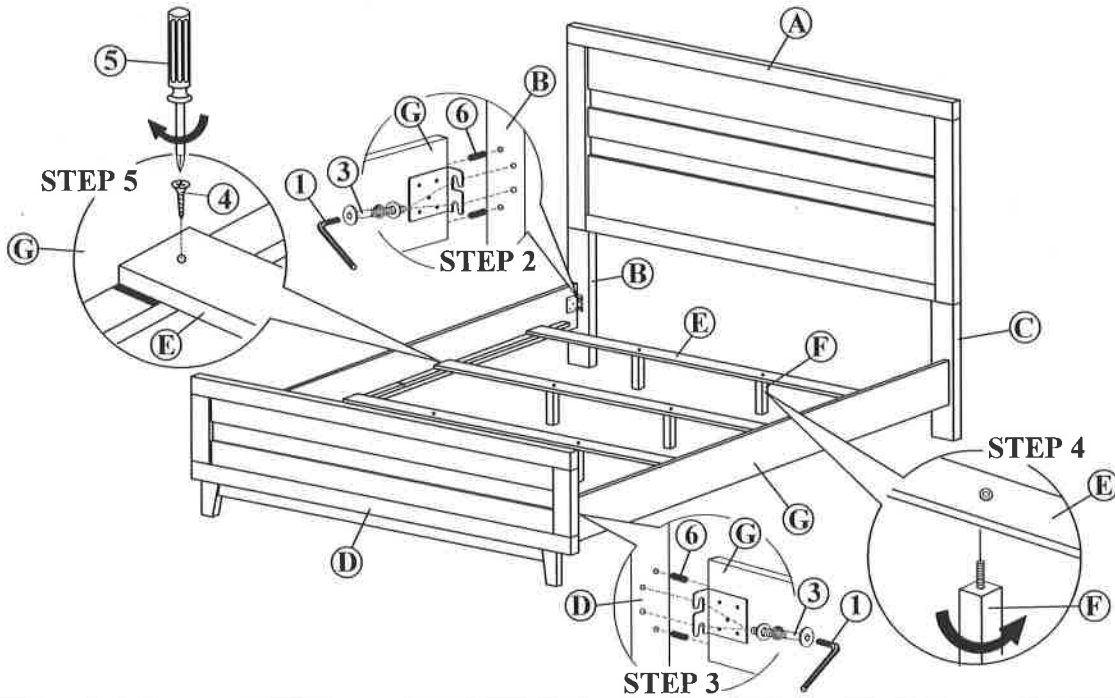

OPTION 2 - CALIFORNIA KING BED

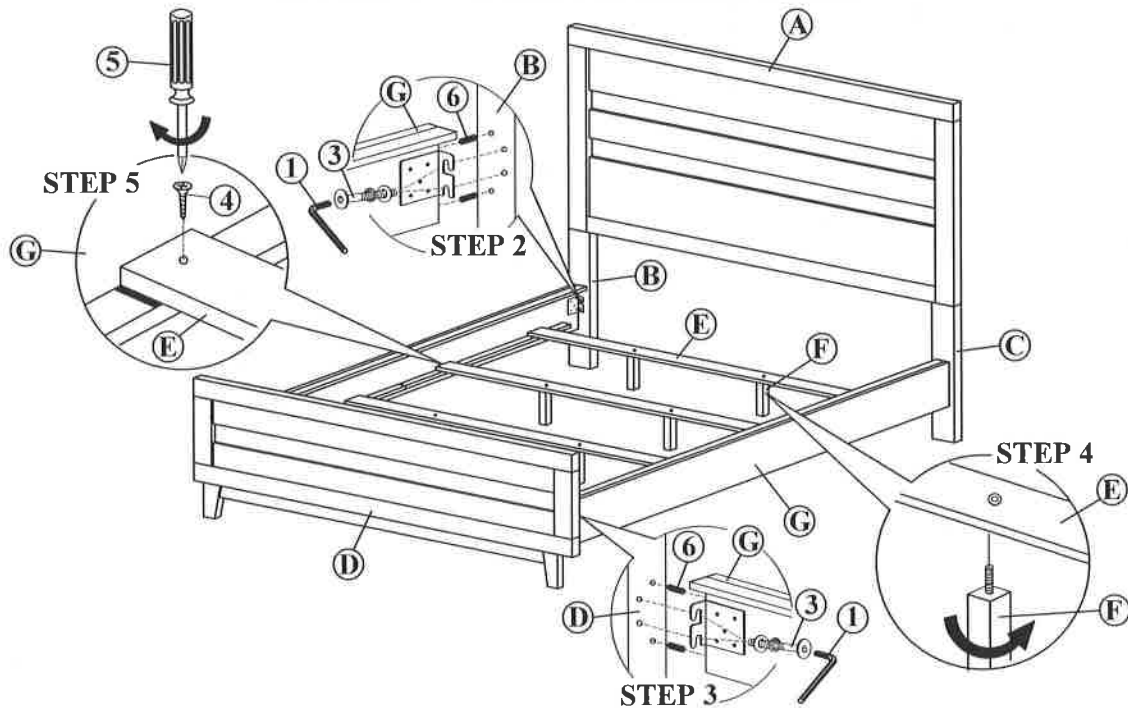

THE HARDWARE IS LOCATED IN THE PACKING ITEMS

NOTE : MUST TIGHTEN SCREWS PERIODICALLY. WITH USE SCREW MAY BECOME LOOSE.
CHECK TIGHTNESS OF ALL SCREW EVERY 6-8 WEEKS.

CLEANING INSTRUCTION







After assembly, clean & polish the completed parts if necessary with soft cloth and industrial recognized furniture polish

MADE IN MALAYSIA





ASSEMBLY INSTRUCTIONS

ITEM NO : B8270 / B8280 - CK - RAIL
CALIFORNIA KING SIDE RAIL

**(BOX 1)
BOX OF HEADBOARD / FOOTBOARD**

ITEM	DRAWING	DESCRIPTION	QTY
A		HEADBOARD PANEL	1
B		LEFT HEADBOARD LEG	1
C		RIGHT HEADBOARD LEG	1
D		FOOTBOARD	1
E		WOODEN SLAT	4
F		WOODEN SUPPORT	8

**(BOX 1) HEADBOARD / FOOTBOARD
HARDWARE LIST**

ITEM	DRAWING	DESCRIPTION	QTY
1		ALLEN WRENCH (M4)	1
2		CONNECTION BOLT (M6 x 50mm) W/WASHER & SPRING WASHER	8
3		CONNECTION BOLT (M6 x 25mm) W/WASHER & SPRING WASHER	8
4		FLAT HEAD SCREW (#8 x 1 1/8")	8
5		Assembly Tool Not Included	1



**COMPLETED
CALIFORNIA KING BED
ASSEMBLY**

**(BOX 2)
BOX OF SIDE RAIL**

ITEM	DRAWING	DESCRIPTION	QTY
G		SIDE RAIL	2

**(BOX 2) SIDE RAIL
HARDWARE LIST**

ITEM	DRAWING	DESCRIPTION	QTY
6		WOOD DOWEL (M8 x 30mm)	8

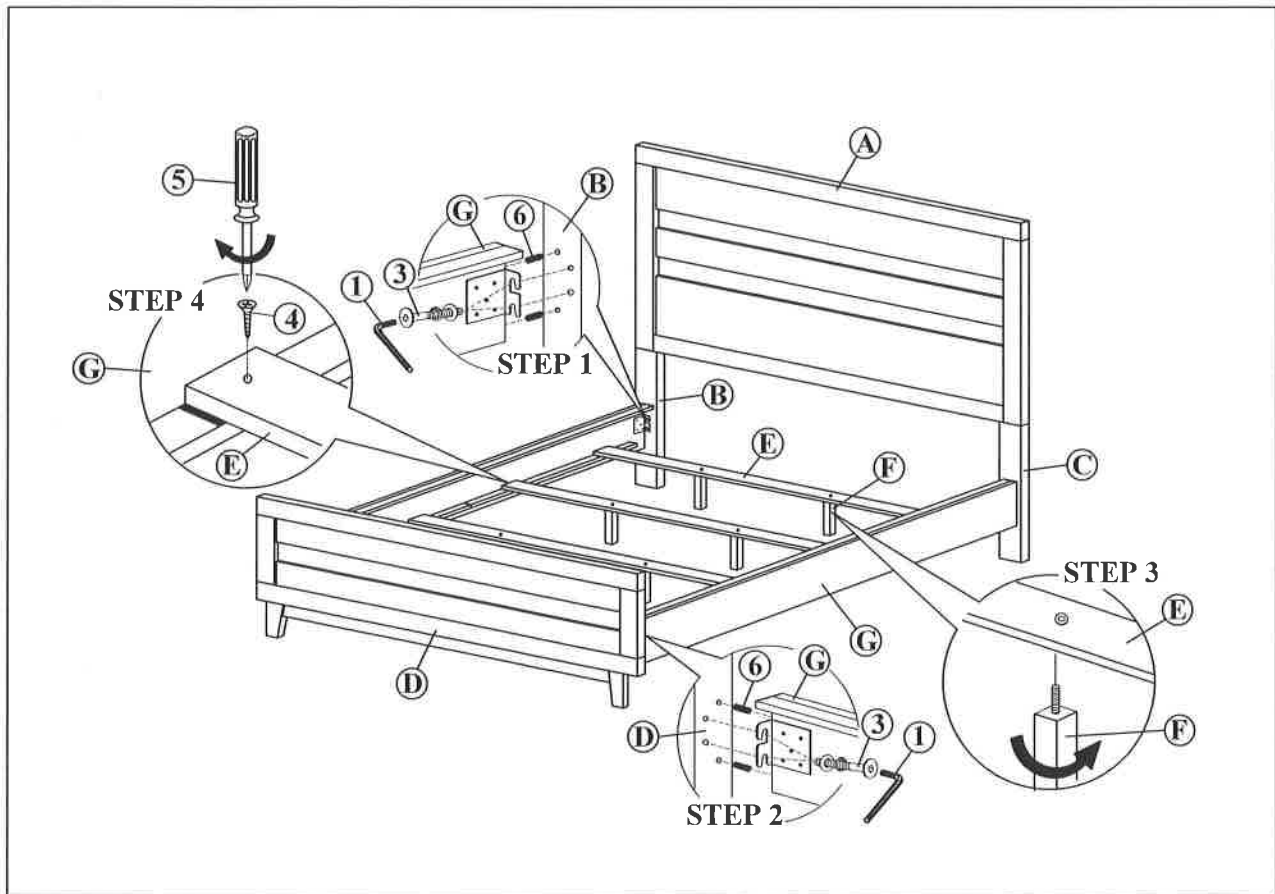

THE HARDWARE LIST IS LOCATED IN THE HEADBOARD, FOOTBOARD & SLATS

NOTE : MUST TIGHTEN SCREWS PERIODICALLY. WITH USE SCREW MAY BECOME LOOSE.
CHECK TIGHTNESS OF ALL SCREW EVERY 6-8 WEEKS.

CLEANING INSTRUCTION

After assembly, clean & polish the completed parts if necessary with soft cloth and industrial recognized furniture polish

