



LIVING SPACES

ASSEMBLY INSTRUCTIONS

AUSTEN WHITE KING UPH BED W/ FOOTBOARD STORAGE

SKU:346171/**346529**/346637



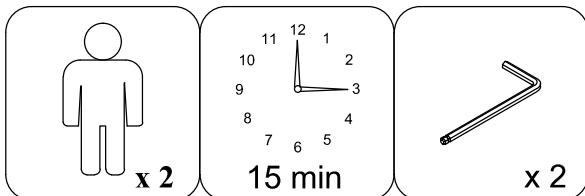
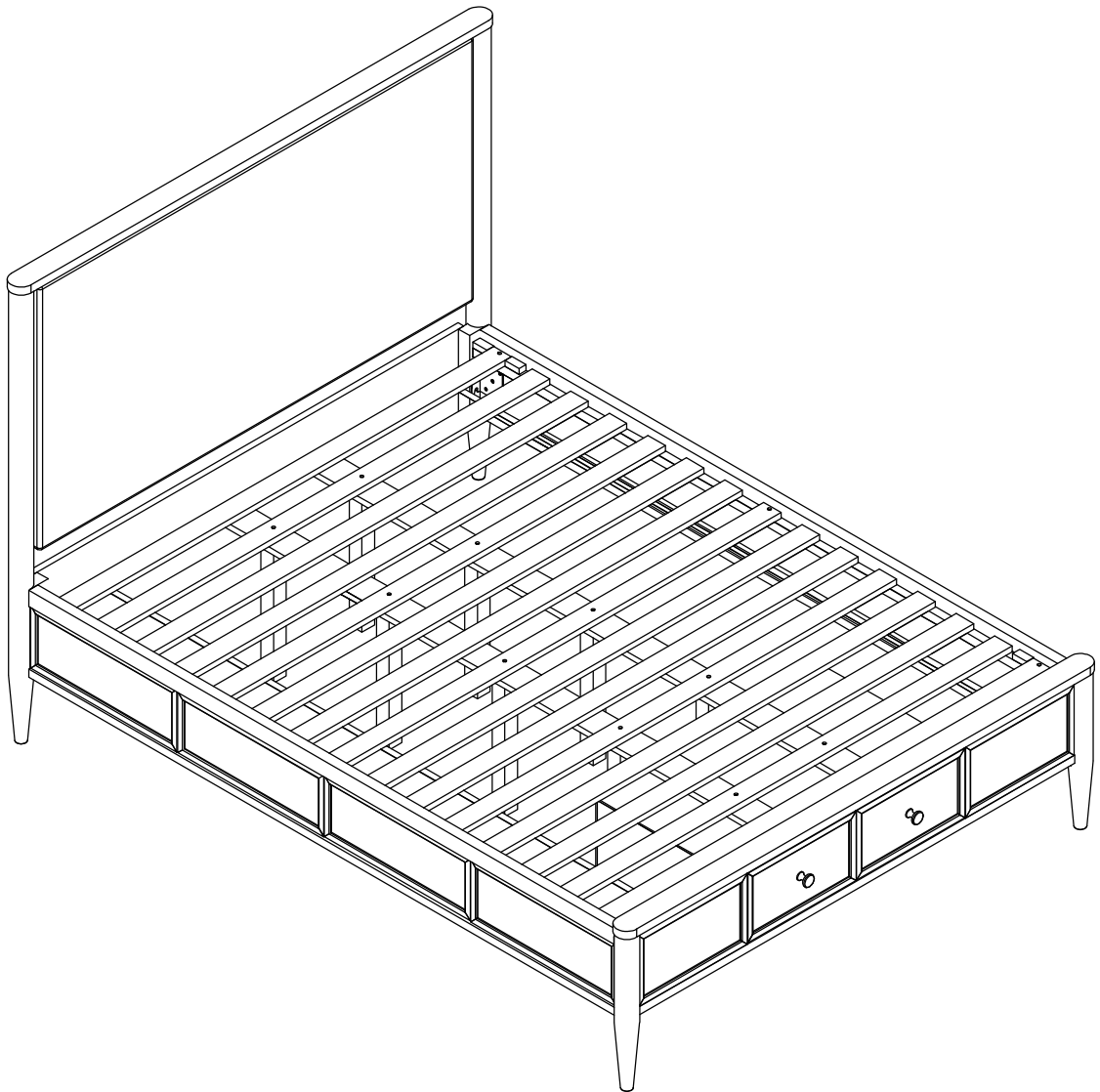

AUSTEN WHITE KING PANEL BED W/ FOOTBOARD STORAGE

SKU:346099/**346529**/346637





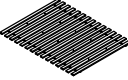
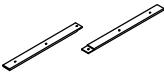
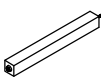



NO	COMPONENT'S SKU	QUANTITY (Cartons)
1	346171/346099	1
2	346529	1
3	346637	1



1

PART	COMPONENT'S SKU	PART LIST Number	IMAGE	DECRPTION	QTY
(A)	346171/346099	346171/346099		Head Board	1
(B)	346529	346529-01		Storage Foot Board	1
(C)		346529-02		Foot Board back leg	2
(D)		346529-03		Slat	1 set
(E)		346529-04		Middle Support Bar	4
(F)		346529-05		Support With Leveler	10
(G)	346637	346637-01		Side Rail	2

Hardware List

PART	COMPONENT'S SKU	Hardware List	IMAGE	DECRPTION	QTY
(1)	346529	346529-A01		Screw #8* 30mm	6
(2)		346529-A02		Bolts 1/4" *38mm	2
(3)		346529-A03		Spring Washer 1/4"*11mm	2
(4)		346529-A04		Flat Washer 1/4" *19mm	2
(5)		346529-A05		Allen key	1
(6)	346637	346637-A01		Bolts 5/16" *25mm	8
(7)		346637-A02		Spring Washer 5/16" Dia	8
(8)		346637-A03		Flat Washer 5/16" * Dia	8
(9)		346637-A04		Allen key	1

THE HAEDWARE IS LOCATED IN THE PACKING ITEM

MUST: TIGHTEN SCREWS PERIODIACLLY. WITH USE SCREW MAY ENCOME LOOSE CHECK TIGHTNESS OF ALL SCREWS EVERY 6-8 WEEKS.

CLEANING INSTRUCTIONS:

After assembly, clean and polish the completed parts if necessary with soft cloth and industrial recognized furniture polish.

STEP 1

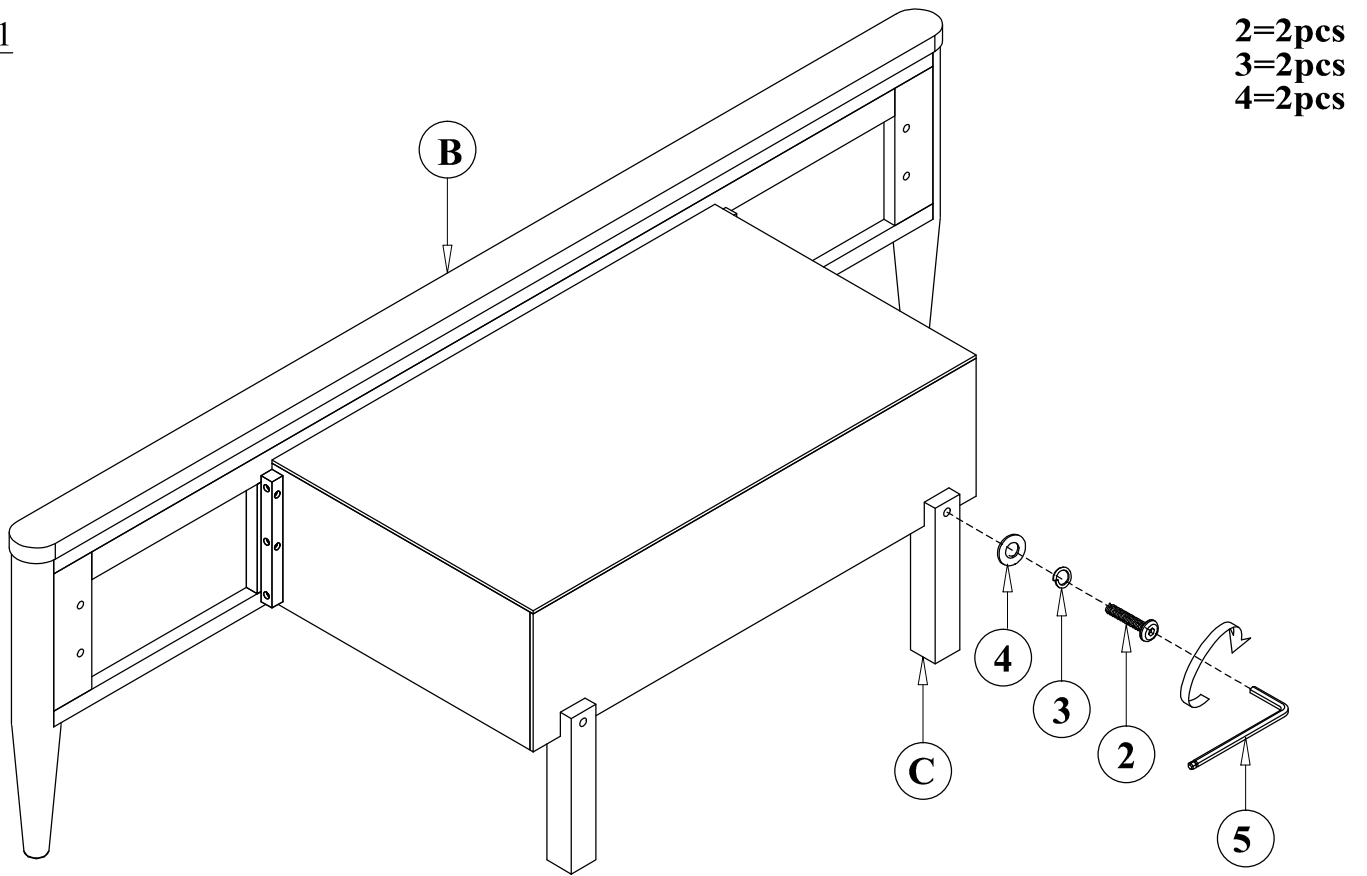

STEP 2

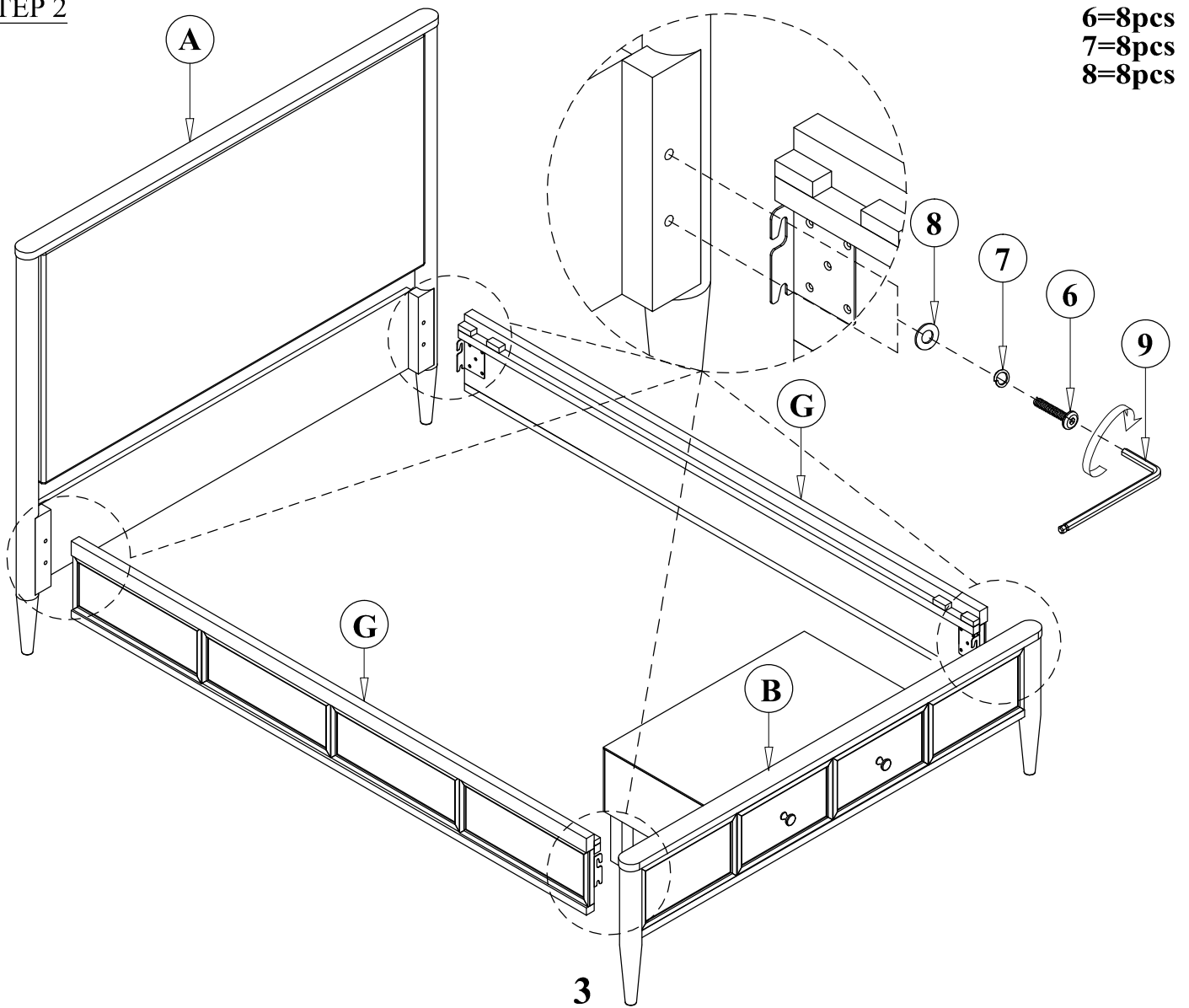

STEP 3

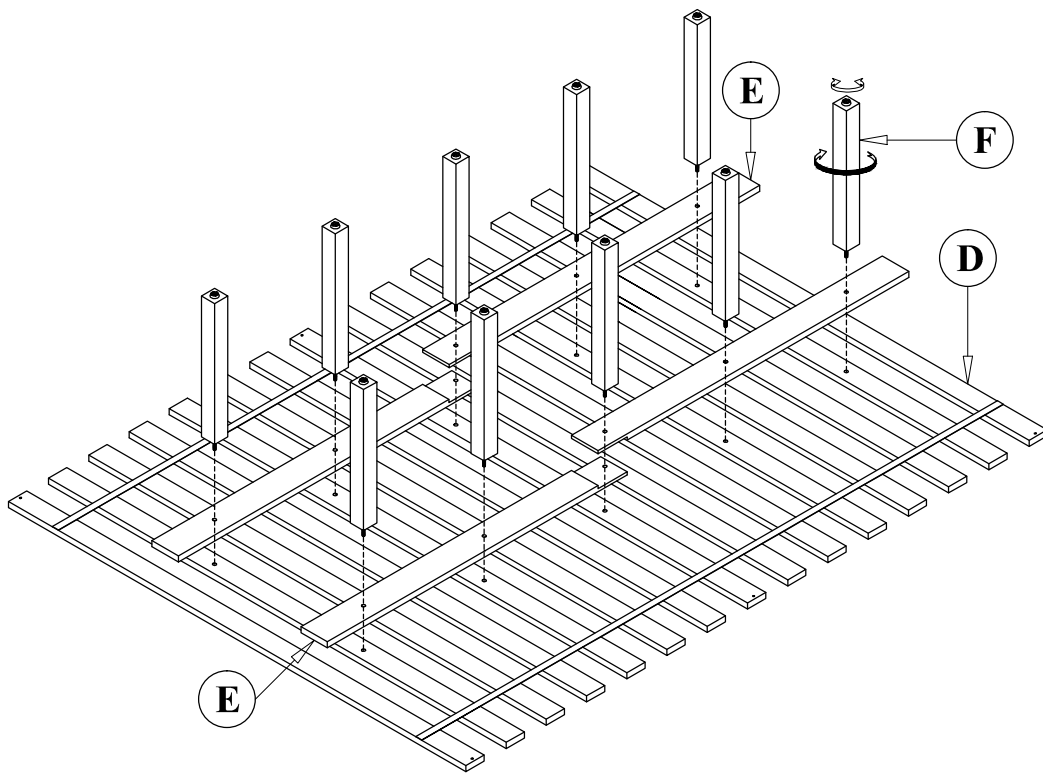

STEP 4

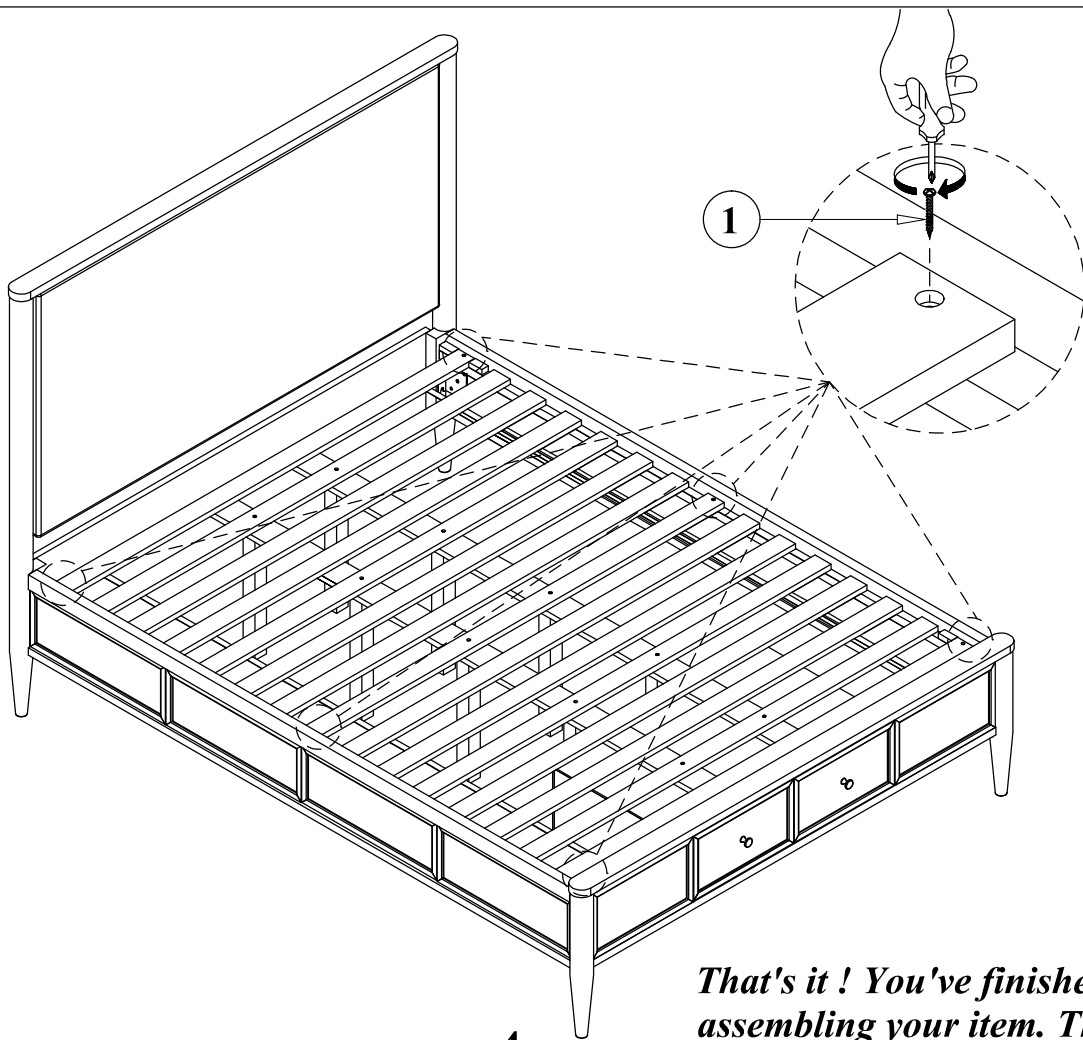

That's it ! You've finished assembling your item. Thank you!