



LIVING SPACES

ASSEMBLY INSTRUCTIONS

AUSTEN CALIFORNIA KING UPH BED

SKU:318034/318024/318058





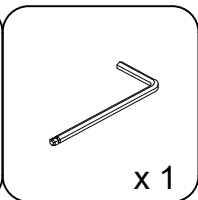
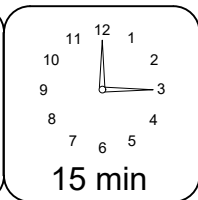
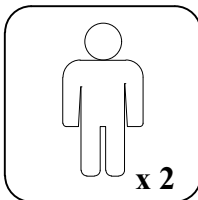
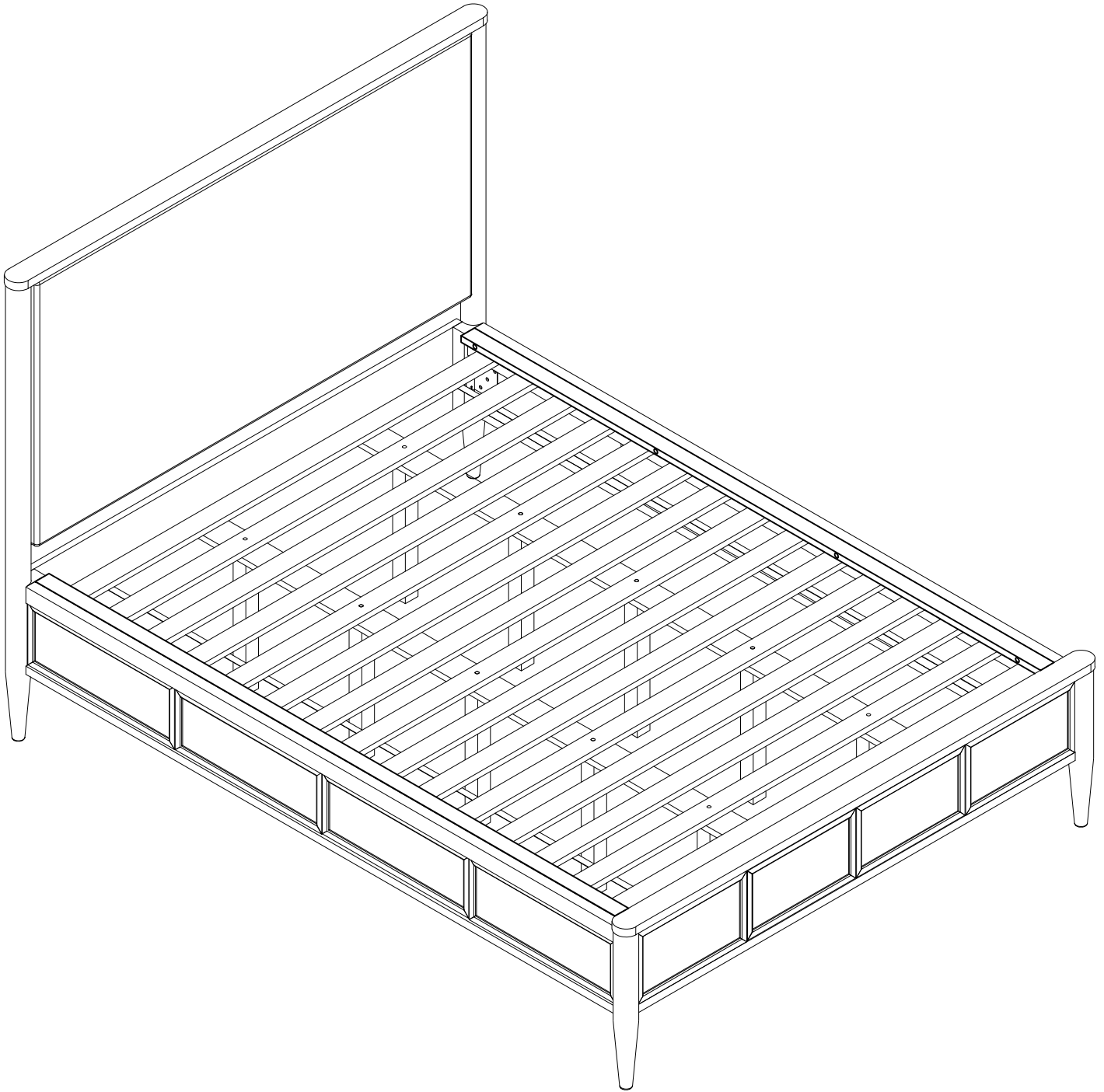

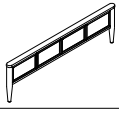
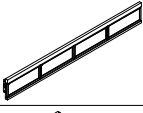
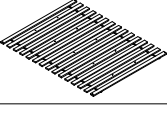
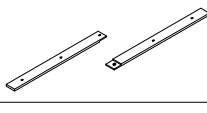
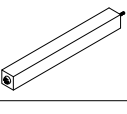
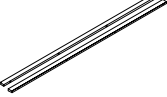
AUSTEN CALIFORNIA KING PANEL BED

SKU:337945/318024/318058

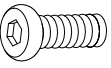

PART	SKU#	IMAGE	DESCRIPTION	QTY
(A)	318034/337945		Head Board	1
(B)	318024		Foot Board	1
(C)	318058		Side Rail	2
(D)	318024		Slat	1 set
(E)	318024		Middle Support Bar	4
(F)	318024		Support With Leveler	10
(G)	318058		Cap Rail	2

Hardware List

PART	SKU#	IMAGE	DESCRIPTION	QTY
(1)	318058		Bolts 5/16" *25mm	8
(2)	318058		Spring Washer 5/16" Dia	8
(3)	318058		Flat Washer 5/16" * Dia	8
(4)	318058		Allen key	1
(5)	318024		Screw #8* 30mm	6
(6)	318058		Bolts 1/4" *45mm	8

THE HARDWARE IS LOCATED IN THE PACKING ITEM

MUST: TIGHTEN SCREWS PERIODICALLY. WITH USE SCREW MAY ENCOME LOOSE CHECK TIGHTNESS OF ALL SCREWS EVERY 6-8 WEEKS.

CLEANING INSTRUCTIONS:

After assembly, clean and polish the completed parts if necessary with soft cloth and industrial recognized furniture polish.

STEP 1

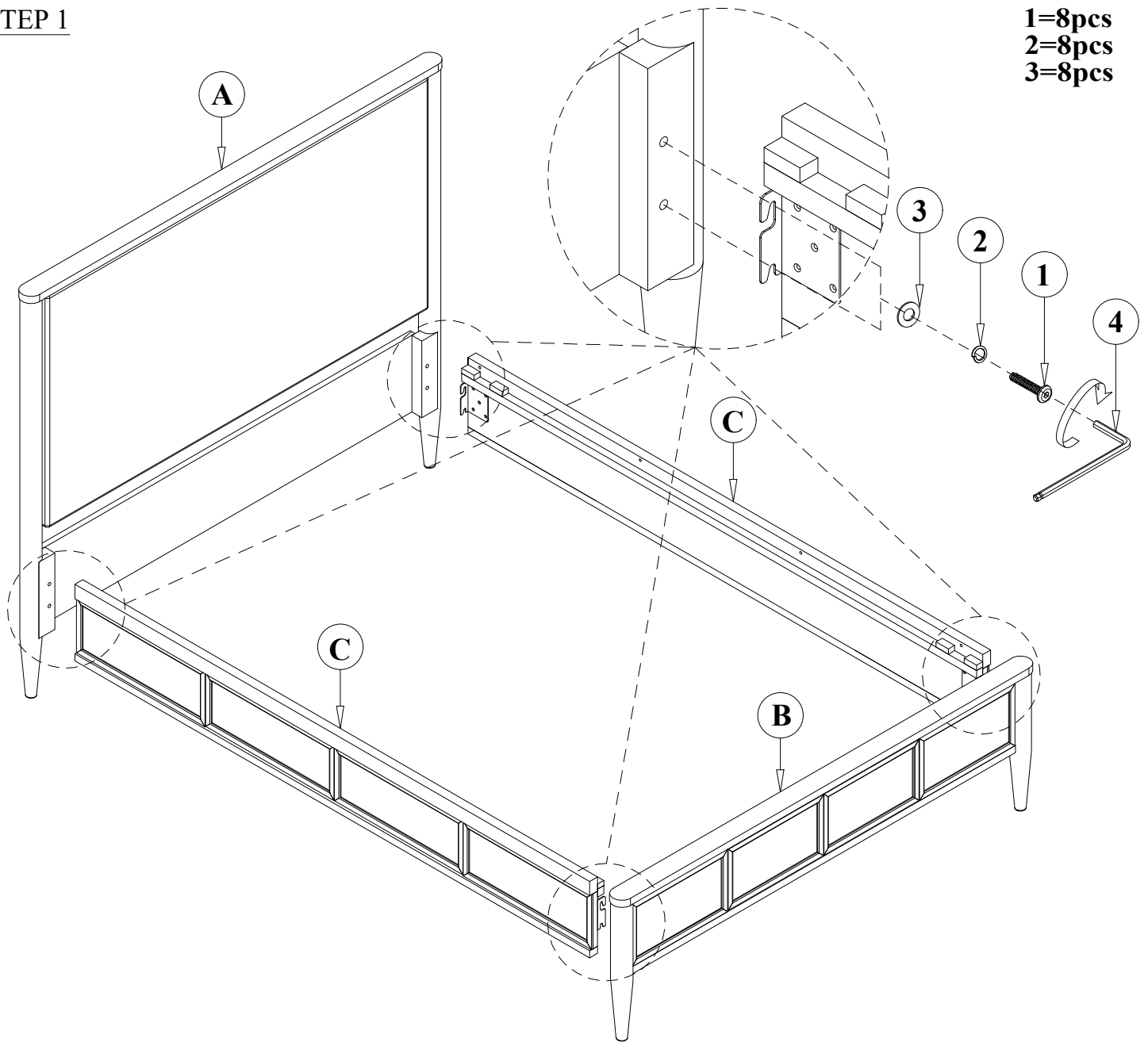

STEP 2

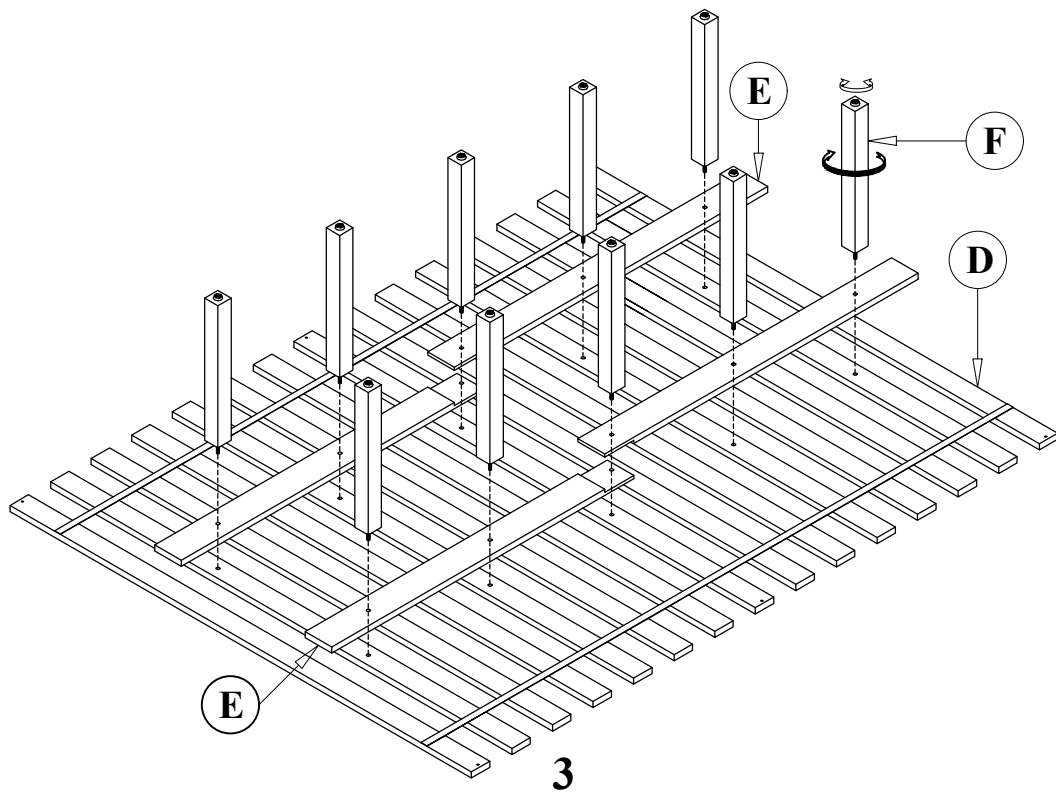

STEP 3

5=6pcs

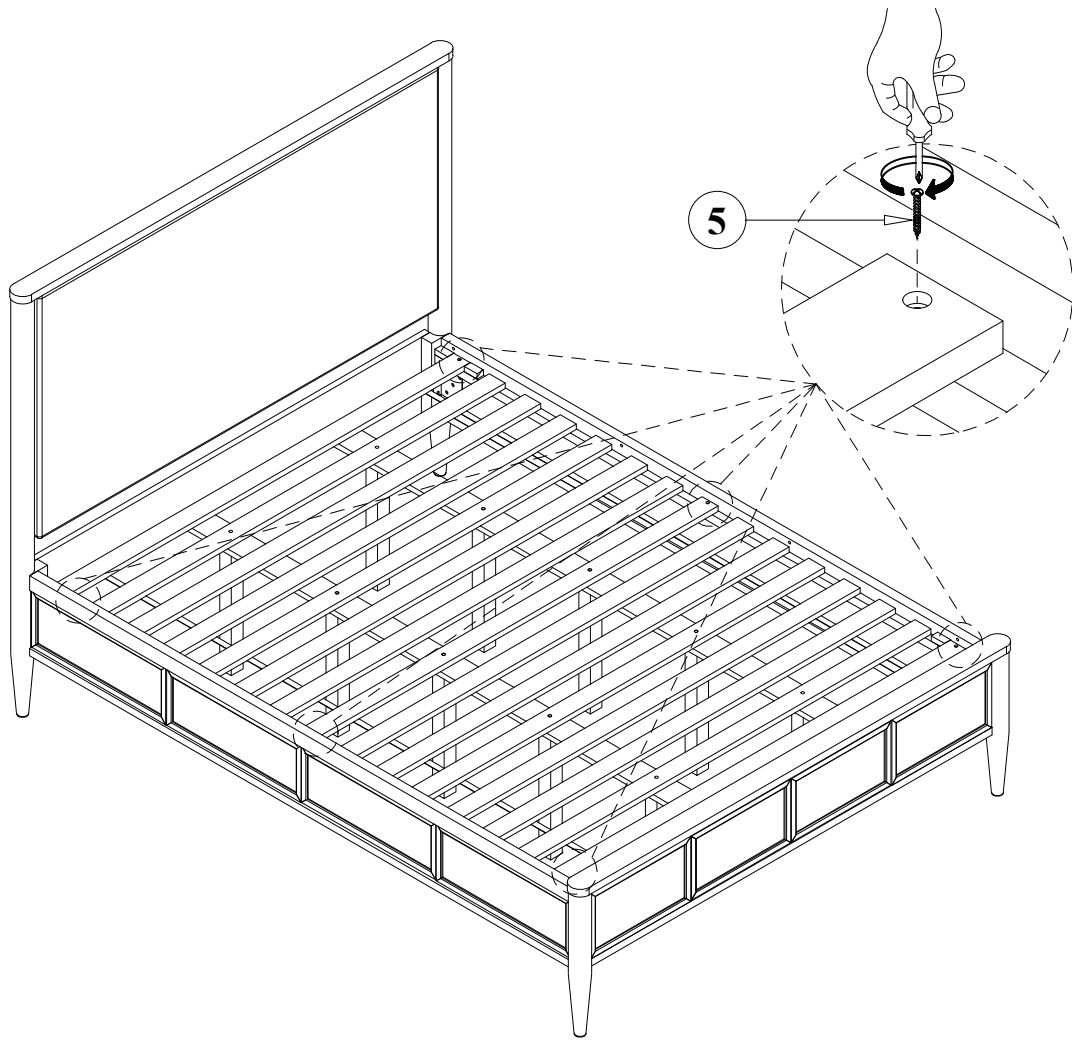

STEP 4

6=8pcs

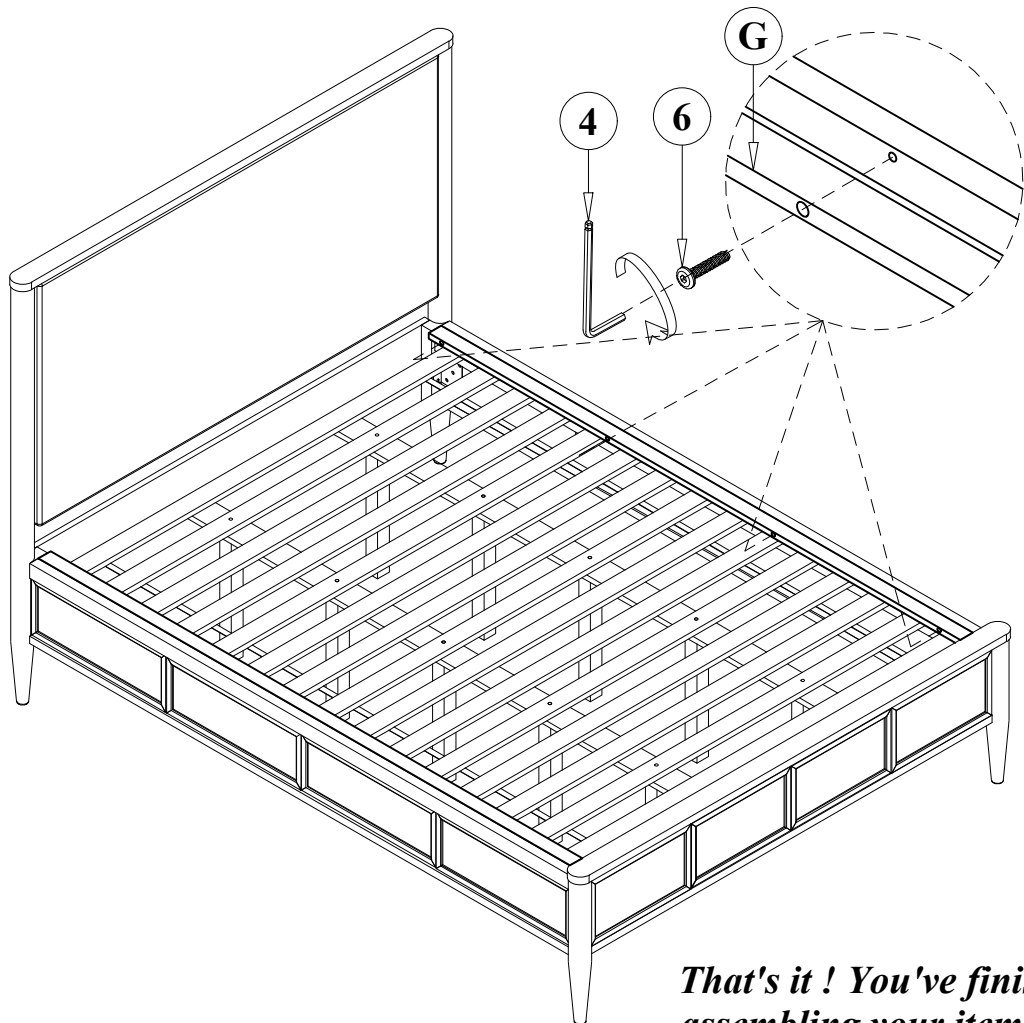

That's it ! You've finished assembling your item. Thank you!