

ASSEMBLY INSTRUCTIONS

CROWNMARK
B4610/B4630-K-HBFB-CK-RAIL
C.KING (4+8)

(Box 1)
 BOX OF HEADBOARD & FOOTBOARD

No	ITEM	Qty
A	Headboard	1 pc
B	Footboard	1 pc
C	Headboard Leg (L/R)	2 pcs
D	Bed Slats	4 pcs
E	Bed Slats Support	8 pcs

(Box 2)
 BOX OF SIDE RAIL

No	ITEM	Qty
F	Side Rail	2 pcs

(Box 1)
 HARDWARE LIST

No	ITEM	Qty
1	JCBC M6 x 30mm	6 pcs
2	SPRING WASHER 1/4" Rbw	6 pcs
3	Flat Washer 1/4"ID x 13mmOD Blk	6 pcs
4	ALLEN KEY m4x65mm Blk	1 pc
5	ALLEN KEY m5x65mm Blk	1 pc

(Box 2)
 HARDWARE LIST

No	ITEM	Qty
6	PAN HEAD CHIPBOARD SCREW m3.5 x 16mm RBW	16 pcs
7	L-Bracket BLK	8 pcs

STEP 1 : Attach Head Board Leg (B) to Head Board (A) as shown using JCBC BOLT(1)with Spring Washer (2), Flat washer (3) and securing with ALLEN KEY (4).

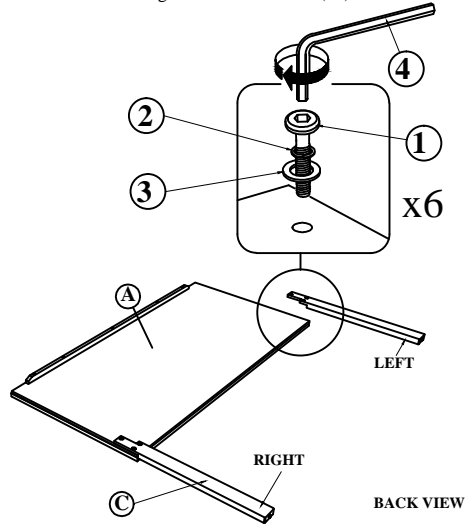

STEP 2 : Hook SIDE RAIL (F) TO HEAD BOARD (A) closely and push down to fit. repeat step 2 with other end of rail to hook onto FOOTBOARD (B).

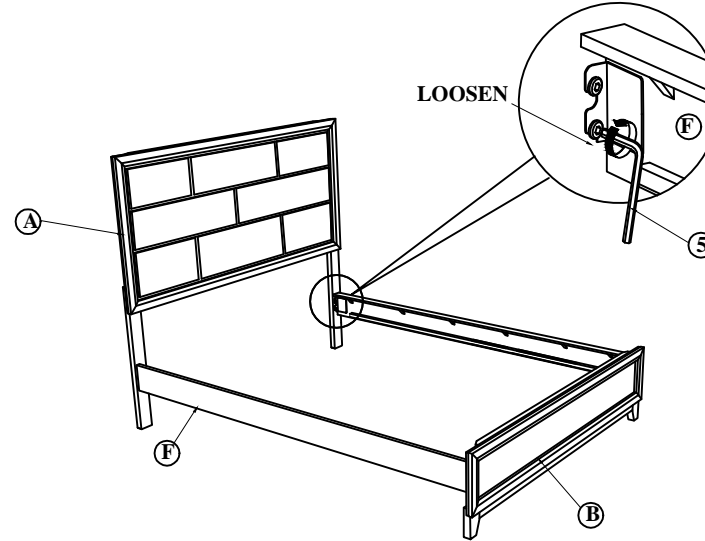

STEP 3 : Tighten the 4 Corner with Allen Key (5). Fix the Bed Slat Support Leg (E), to Bed Slat (D) as shown . Install the bed slat (D) to side rail (F) lastly tighten Bed Slats with L-bracket (7) by using Pan Head Chipboard Screw (6). Loosen or Tighten the Adjuster as necessary to level the bed. Bed assembly should be done in final location to ensure stability.

STEP 3.2 :

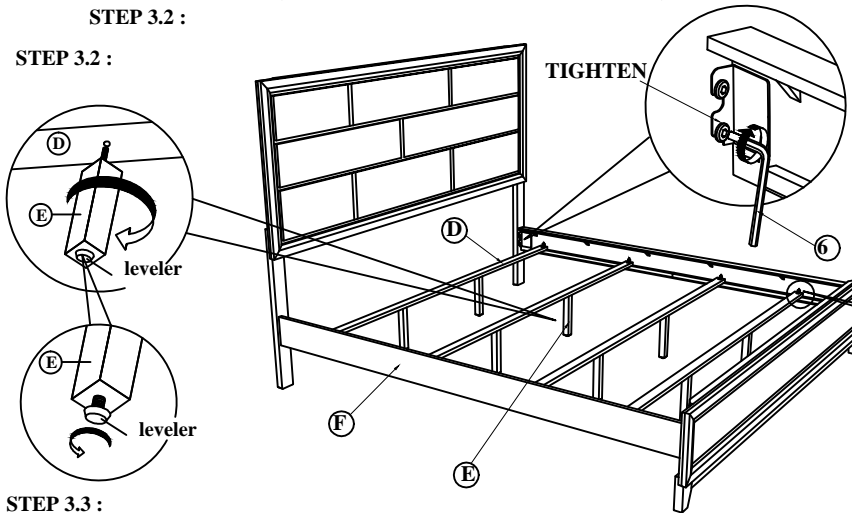

STEP 3.3 :

STEP 3.1 :

x8

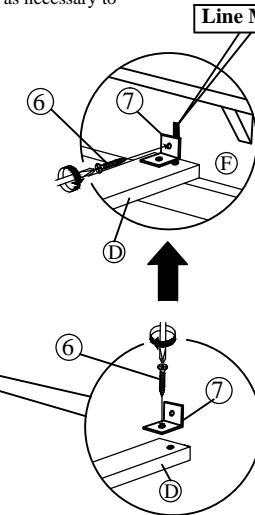

STEP 3.5 :

STEP 3.4 :

REMARK

Make sure adjust the L-bracket accordingly before tighten at side rail.

NOTE : MUST TIGHTEN SCREWS PERIODCALLY WITH USE SCREW WILL BECOME LOOSE CHECK TIGHTNESS OF ALL SCREW EVERY 6-8 WEEKS.