

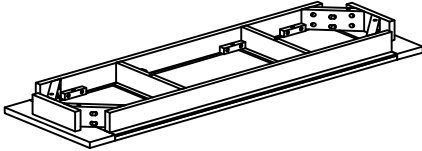

Parts List

Sku #	Image	Description	Q.ty
#2674		Top Frame	1
#2675		Legs	4
#2676		Cushion	1

Hardware List

Sku #	Image	Description	Q.ty
#1002		Conection Bolts (M8x60) Spring Washers Flat Washers	8 Sets
#2001		Allen key K4	1 Pc

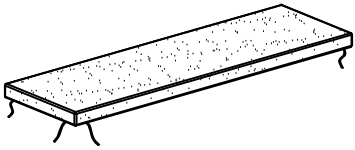
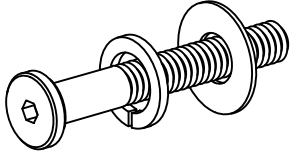
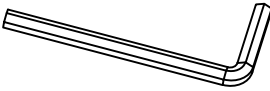
ASSEMBLY INSTRUCTION

DINING BENCH
ITEM NO. : 267684

STEP 1

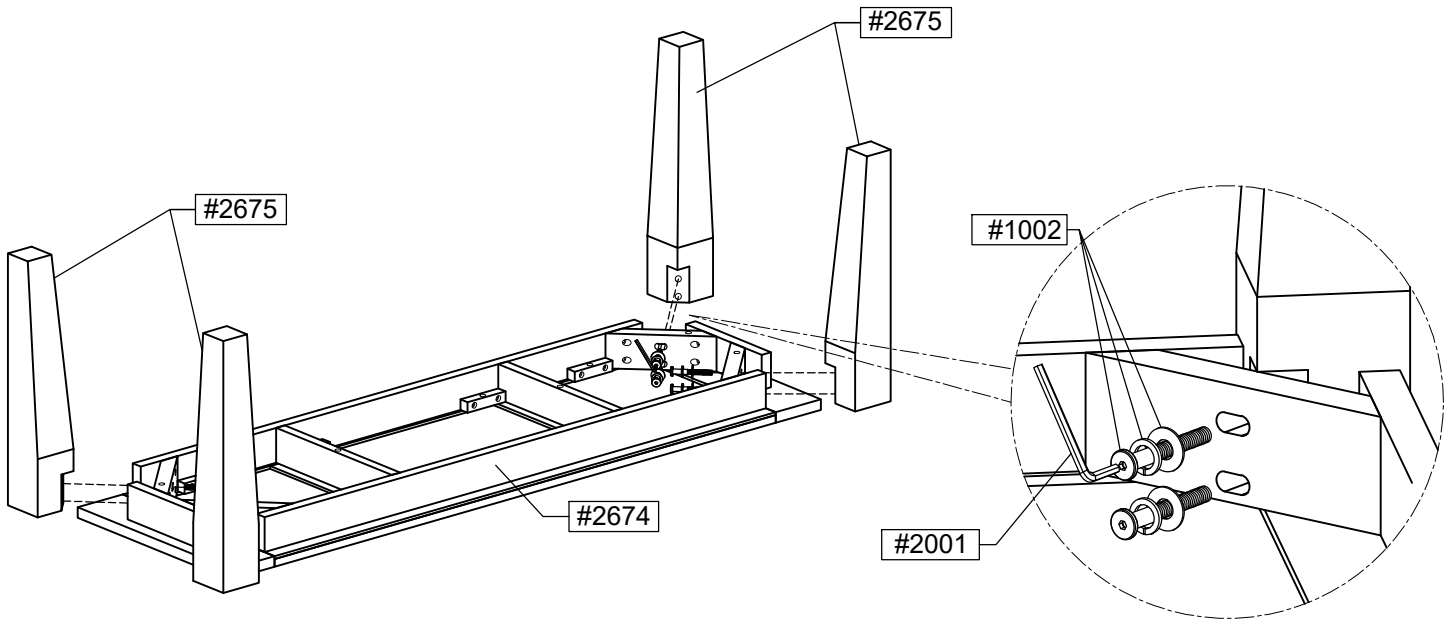

STEP 2

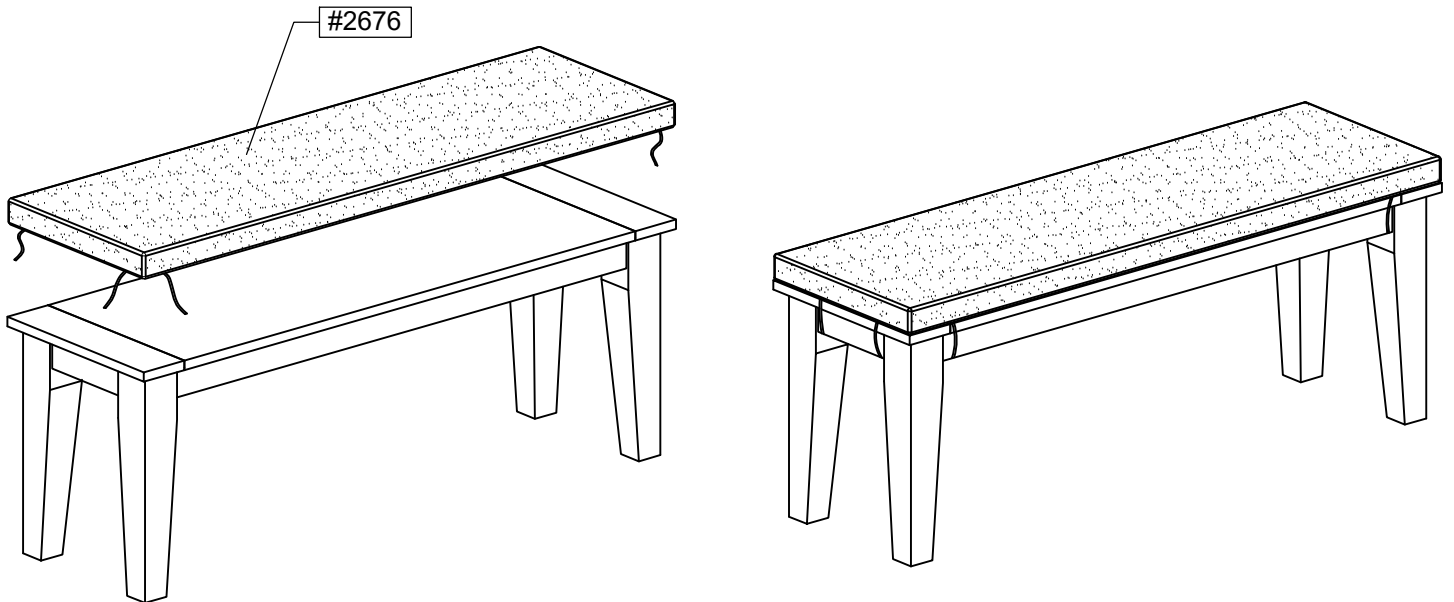

ASSEMBLY COMPLETE

THE HARDWARE IS LOCATED IN THE PACKING ITEMS

NOTE: MUST TIGHTEN BOLTS PERIODICALLY. WITH USE BOLT MAY BECOME LOOSE CHECK TIGHTNESS OF ALL BOLTS EVERY 6-8 WEEKS

CLEANING INSTRUCTIONS

After assembly, clean & polish the completed parts if necessary with soft cloth and industrial recognized furniture polish