

LIVING SPACES

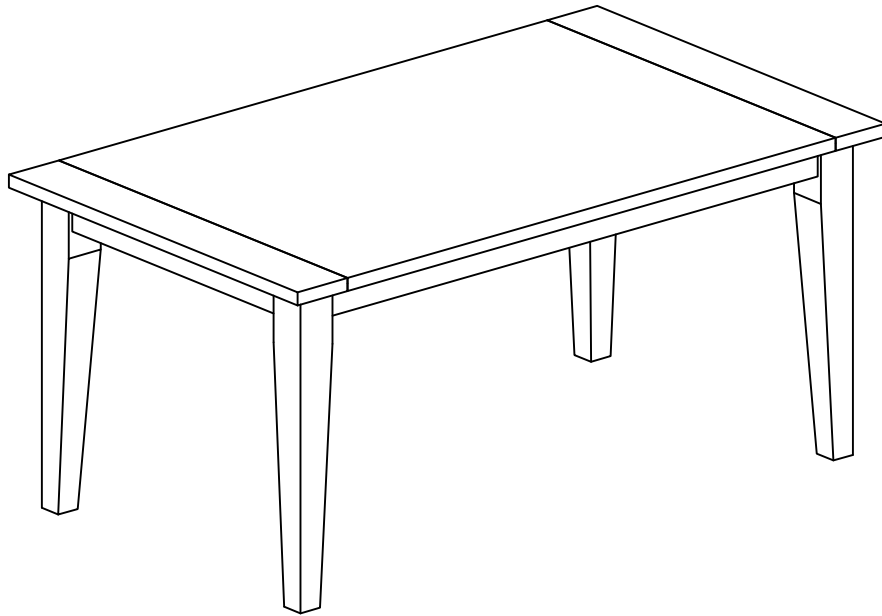

# ASSEMBLY INSTRUCTION

FIXED DINING TABLE 1650

ITEM NO. : 267683

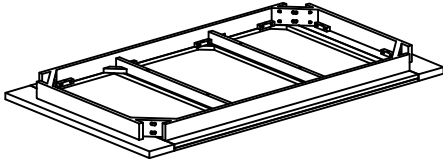

## Parts List

Sku #	Image	Description	Q.ty
#2672		Top Frame	1
#2673		Legs	4

## Hardware List

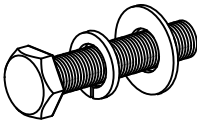
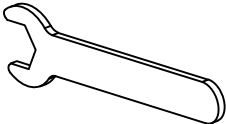
Sku #	Image	Description	Q.ty
#1001		Conection Bolts (M10x60) Spring Washers Flat Washers	8 Sets
#2003		Spanner	1 Pc



**LIVING SPACES**

# ASSEMBLY INSTRUCTION

FIXED DINING TABLE 1650

ITEM NO. : 267683

## STEP 1

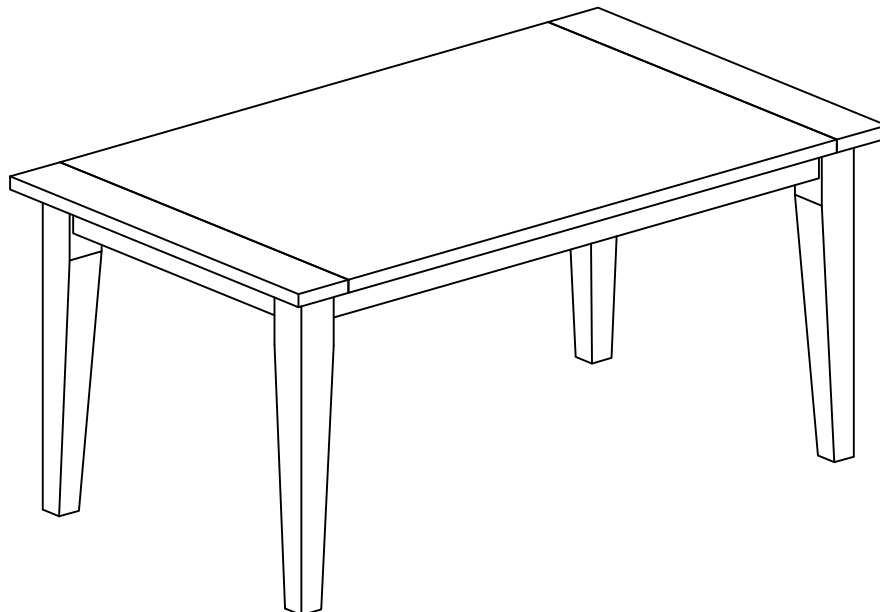
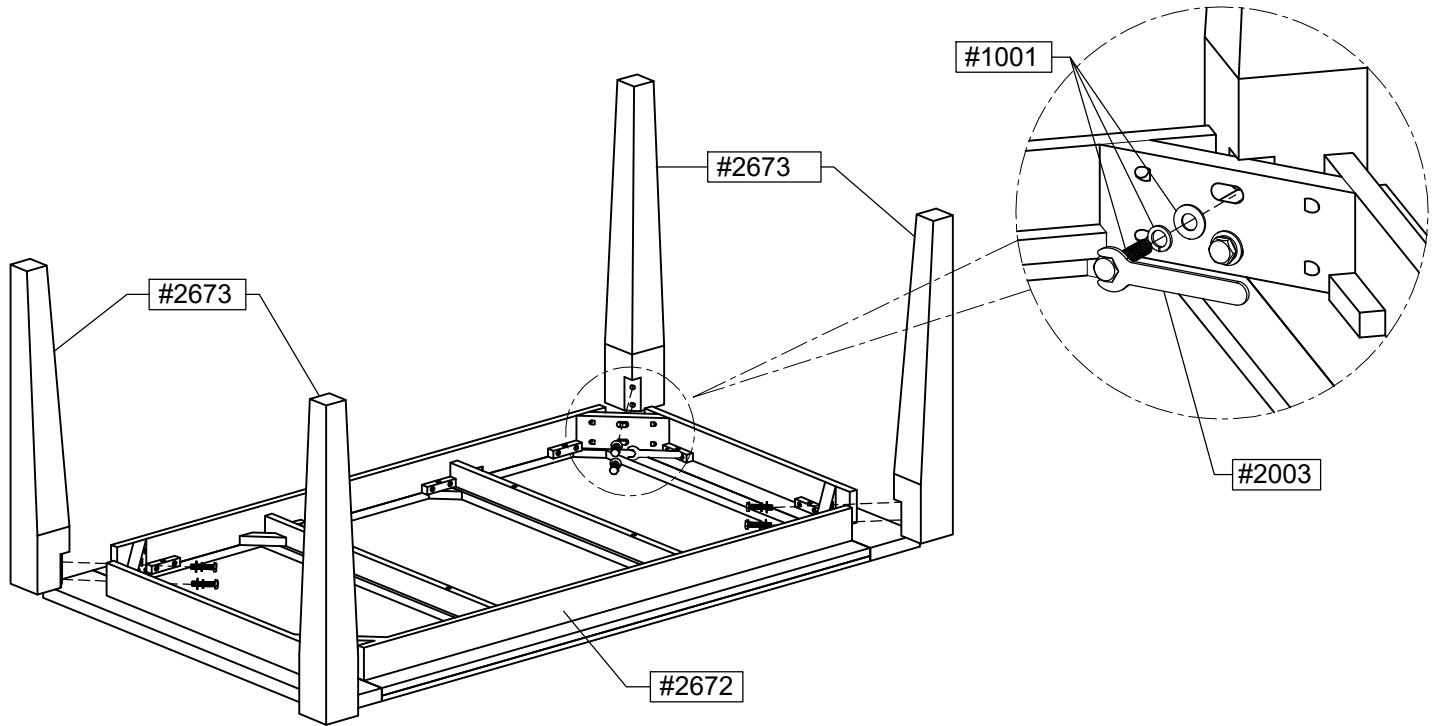

**ASSEMBLY COMPLETE**

THE HARDWARE IS LOCATED IN THE PACKING ITEMS

NOTE: MUST TIGHTEN BOLTS PERIODICALLY. WITH USE BOLT MAY BECOME LOOSE CHECK TIGHTNESS OF ALL BOLTS EVERY 6-8 WEEKS

### CLEANING INSTRUCTIONS

After assembly, clean & polish the completed parts if necessary with soft cloth and industrial recognized furniture polish